

Discovery Place

Equipment Manufacturer



350-1423



Discovery Place

Equipment Manufacturer



350-1423



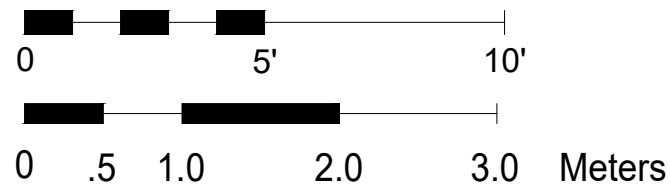
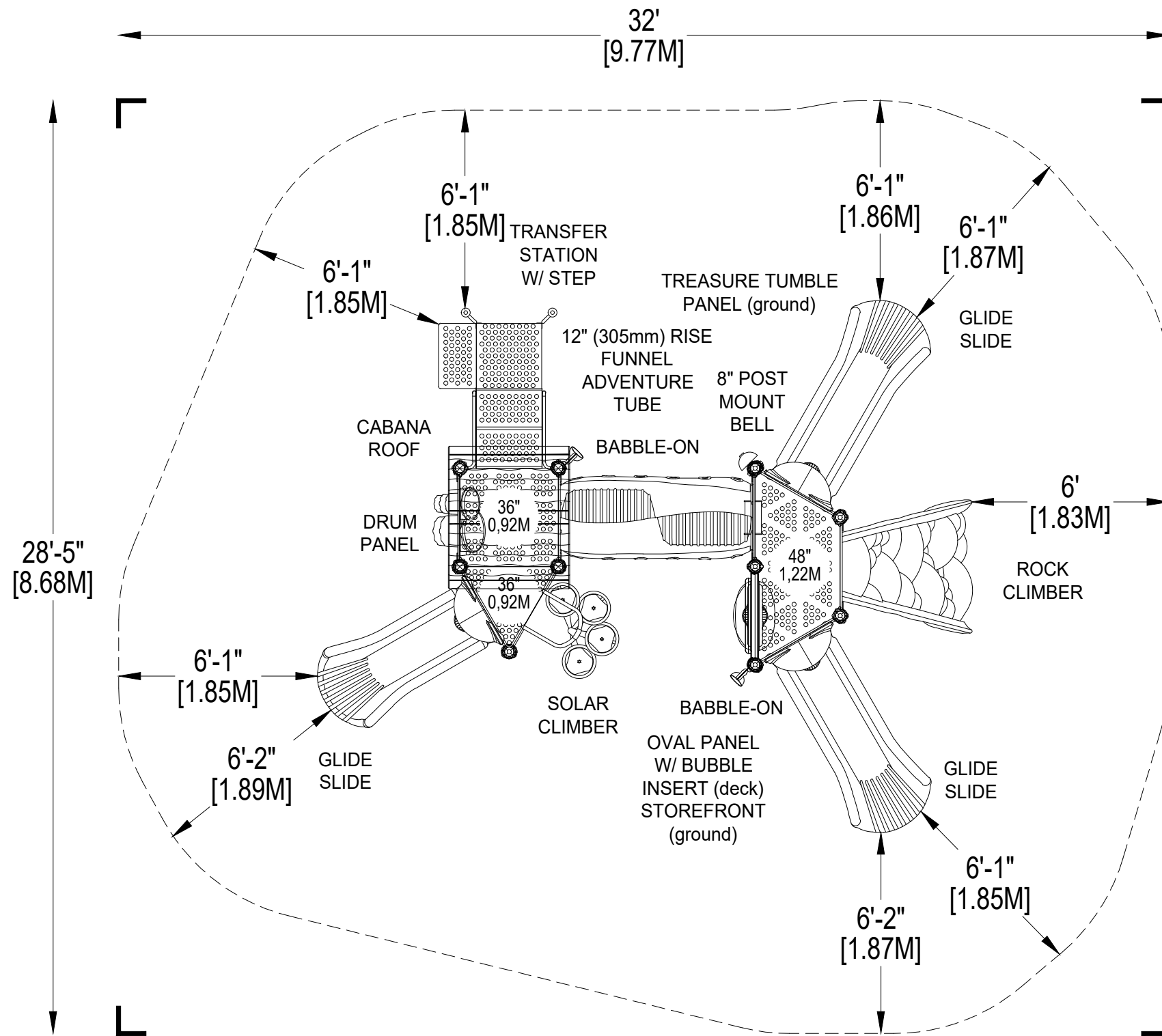

*PLAYGROUND SUPERVISION REQUIRED



PLAYWORLD SYSTEMS, INC.
 1000 Buffalo Road
 Lewisburg, PA
 17837-9795 USA

EQUIPMENT SIZE:
20'0" x 16'3" x 12'3"
 6,1M x 4,95M x 3,73M

USE ZONE:
32'0" x 28'5"
 9,77M x 8,68M

AREA: **764 SqFt.** PERIMETER: **101 Ft.**
 70,98 SqM. 30,78M

FALL HEIGHT:
4 Ft.
 1,22M

USER CAPACITY: **39** AGE GROUP: **2-5**

ADA SCHEDULE	Total Elevated Play Activities: 8		
	Total Ground-Level Play Activities: 4		
	Accessible Elevated Activities	Accessible Ground-Level Activities	Accessible Ground-Level Play Types
Required	4	3	3
Provided	8	3	3

- ✓ ASTM F1487-17
- ✓ CPSC #325



PROJECT NO:
350-1423D

SCALE:
1/4"=1'-0"

DRAWN BY:
M. MERTZ

Paper Size

DATE:
10-NOV-17

B

DISCOVERY PLACE
 CATALOG PRE-DESIGN

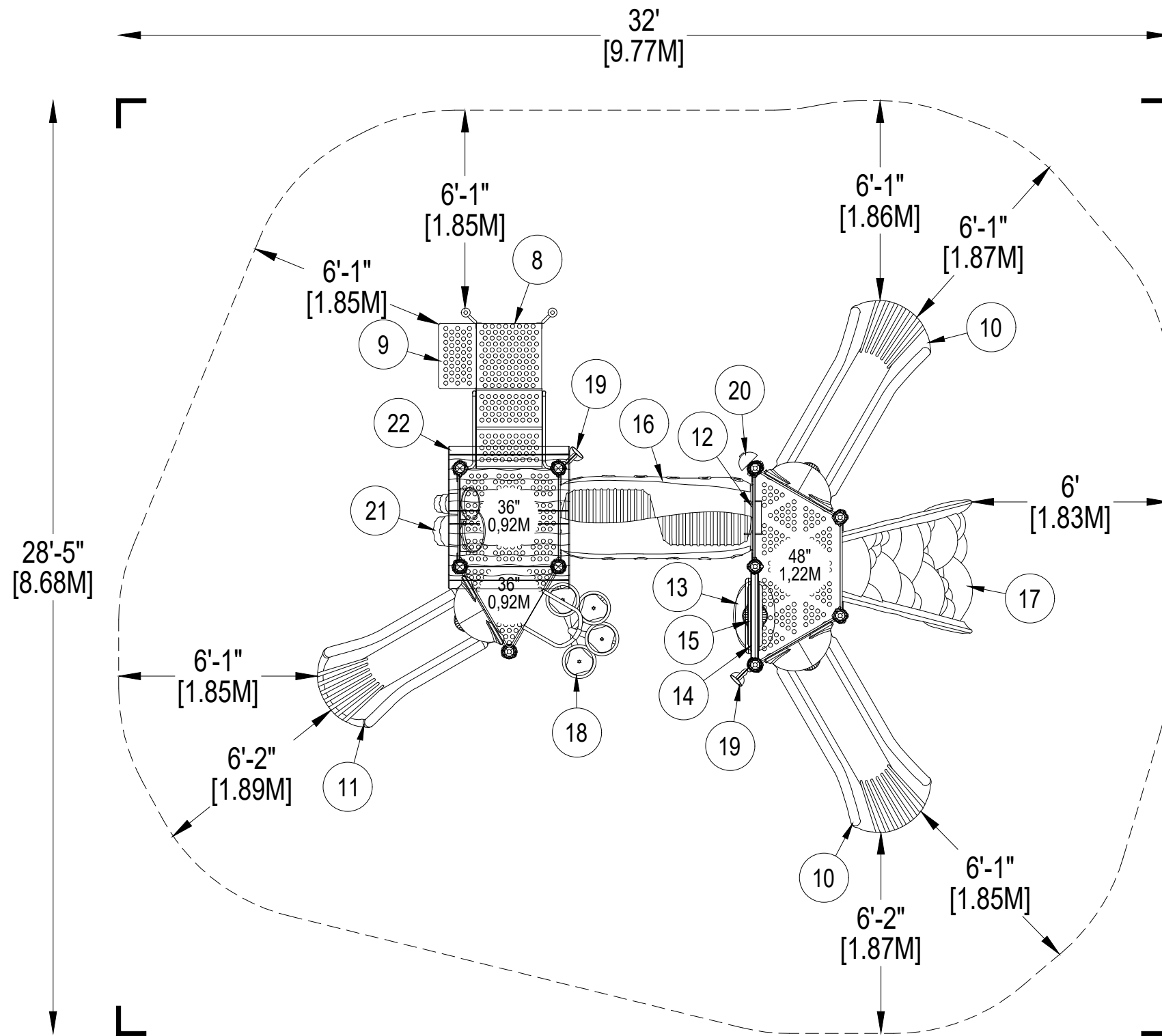

*PLAYGROUND SUPERVISION REQUIRED



PLAYWORLD SYSTEMS, INC.
 1000 Buffalo Road
 Lewisburg, PA
 17837-9795 USA

EQUIPMENT SIZE:
20'0" x 16'3" x 12'3"
 6,1M x 4,95M x 3,73M

USE ZONE:
32'0" x 28'5"
 9,77M x 8,68M

AREA: **764 SqFt.** PERIMETER: **101 Ft.**
 70,98 SqM. 30,78M

FALL HEIGHT:
4 Ft.
 1,22M

USER CAPACITY: **39** AGE GROUP: **2-5**

ADA SCHEDULE	Total Elevated Play Activities: 8		
	Total Ground-Level Play Activities: 4		
	Accessible Elevated Activities	Accessible Ground-Level Activities	Accessible Ground-Level Play Types
Required	4	3	3
Provided	8	3	3

- ✓ ASTM F1487-17
- ✓ CPSC #325



PROJECT NO:
350-1423D

SCALE:
1/4"=1'-0"

DRAWN BY:
M. MERTZ

Paper Size

DATE:
10-NOV-17

B

DISCOVERY PLACE
 CATALOG PRE-DESIGN

DETAIL 1

Support Post, Spiral Slide and RockBlocks Post Footing Detail

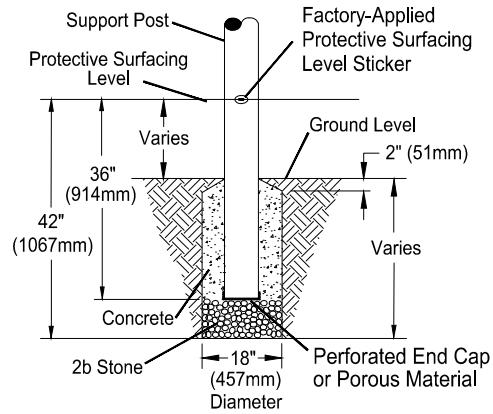

STONE OPTION

OR

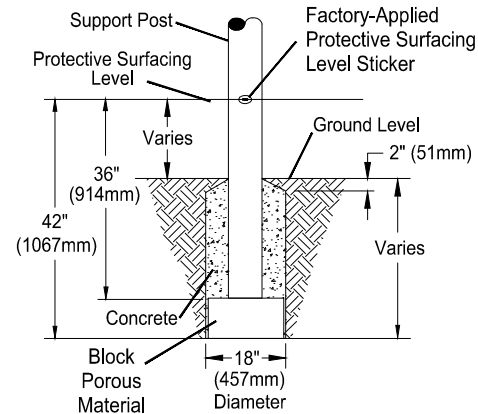

BLOCK OPTION

DETAIL 2

GroundZero, Cantilever and "T" Post Footing Detail



STONE OPTION

OR

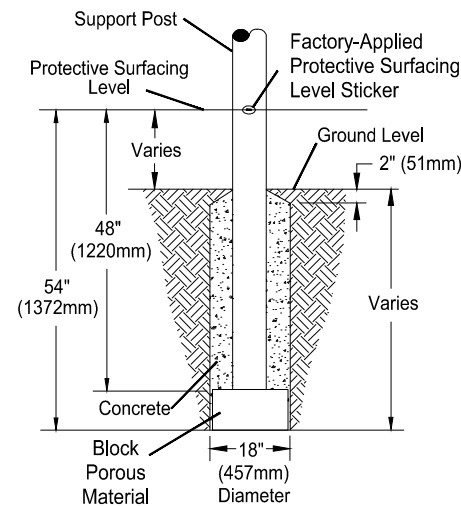

BLOCK OPTION

DETAIL 3

Component Footing Detail

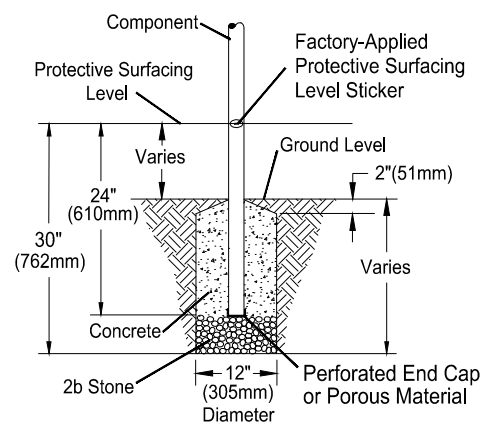

STONE OPTION

OR

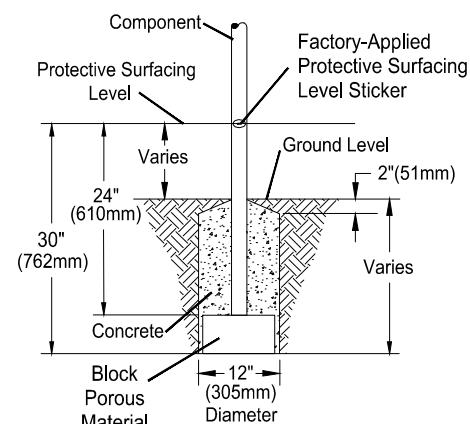

BLOCK OPTION

DETAIL 4

Surface Mount Detail



- INSTALLATION NOTES:**
- 1) Paved surfaces, such as asphalt and concrete, are not acceptable for use under your structure.
 - 2) It is the consumer's responsibility to check with local utilities prior to excavating footings for any underground utility lines that may exist within the installation area.
 - 3) It is the consumer's responsibility to check local soil conditions and drainage within the site area. Inquire with local contractors for appropriate recommendations.
 - 4) If the structure is to be installed across uneven terrain, maintain the support post mark for protective surfacing level at the lowest grade. Adjust other footings accordingly.
 - 5) The base of footings must be below frost lines.
 - 6) Do not encase the bottom of support posts in concrete. Place all posts directly on packed stone.
 - 7) Assemble the entire structure before pouring concrete unless specifically instructed to do so in the individual component installation instructions.
 - 8) Read completely the installation instructions provided with your structure prior to beginning construction.

- SITE NOTES:**
- 1) The site plan provided must be checked against the actual site area to ensure that placement of your structure meets required clearances.
 - 2) The dimensions labeled are for location of footing holes, not exact placement of equipment. Assemble, plumb, and level equipment before pouring concrete.
 - 3) There must be a minimum distance of 6' (1830mm) between any obstacle, sidewalk, etc., and your structure.
 - 4) Slides must have a use zone that extends out from the lower exit section of the slide a distance that is at least 6' (1830mm) or equal to the vertical distance from the highest point of the sliding surface to the top of the protective surfacing, whichever is greater. The slide use zone should not extend greater than 8' (2438mm) from the end of the lower exit section.
 - 5) The complete area, including the space under and around the equipment, must be covered with an impact attenuating material. See the 1997 publication, "Handbook for Public Playground Safety", published by the U.S. Consumer Product Safety Commission, for guidelines and recommendations on the type and depth of surfacing material. For a copy of the "Handbook for Public Playground Safety", write to: **U.S. Consumer Product Safety Commission, Office of Information and Public Affairs, Washington, D.C. 20207**
 - 6) Supervise children as they play.

FOOTING LEGEND

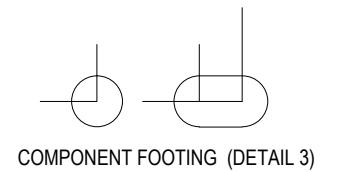

SUPPORT POST FOOTING (DETAIL 1 or 4)
(112" INDICATES POST LENGTH)

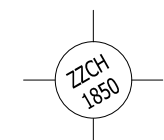

CANTILEVER, "T" POST, AND COMPONENT
POST FOOTING (DETAIL 2)
(ZZCH1850 INDICATES PART NUMBER)

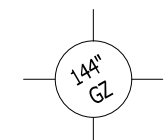

GROUND ZERO POST FOOTING (DETAIL 2)
(144" INDICATES POST LENGTH)

FOOTING DETAIL

SCALE:
NOT TO SCALE

DRAWN BY:
TECH SALES

Paper Size

DATE:
28-JUNE-13

B



PLAYWORLD SYSTEMS, INC.
 1000 Buffalo Road
 Lewisburg, PA
 17837-9795 USA

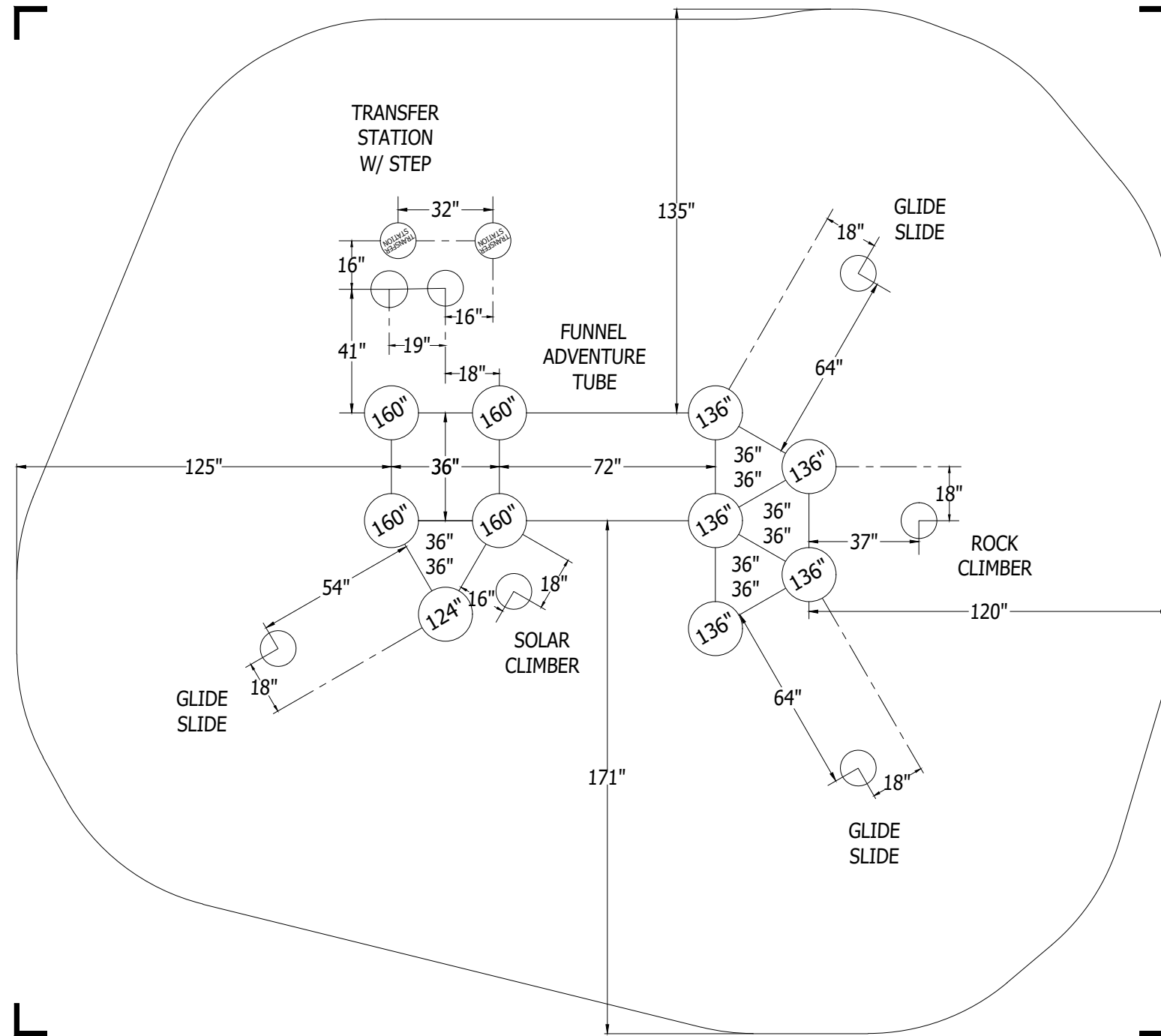

FOOTING LEGEND

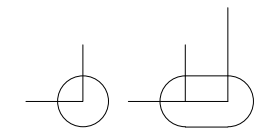

COMPONENT FOOTING (DETAIL 3)

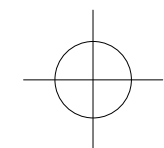

SPIRAL SLIDE CENTER POST FOOTING (DETAIL 1)

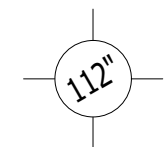

SUPPORT POST FOOTING (DETAIL 1 or 4)
 (112" INDICATES POST LENGTH)

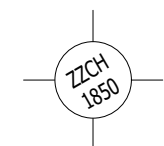

CANTILEVER, "T" POST, AND COMPONENT
 POST FOOTING (DETAIL 2)
 (ZZCH1850 INDICATES PART NUMBER)

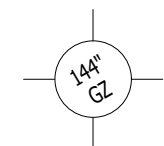

GROUND ZERO POST FOOTING (DETAIL 2)
 (144" INDICATES POST LENGTH)

PROJECT NO:
350-1423D

SCALE:
1/4"=1'-0"

DRAWN BY:
M. MERTZ

Paper Size

DATE:
10-NOV-17

B

*PLAYGROUND SUPERVISION REQUIRED

DISCOVERY PLACE

CATALOG PRE-DESIGN

Discovery Place

Design Number: 350-1423D - Bill Of Material

Ref. No.	Part No.	Description	Quantity
Posts			
1	ZZCH0018	3.5in OD x 124in STEEL POST W/RIVETED CAP	1
2	ZZCH0028	3.5in OD x 136in STEEL POST W/ RIVETED CAP	5
3	ZZCH0049	3.5in OD x 160in STEEL POST W/O CAP	4
Decks & Kick Plates			
4	ZZCH0616	SQUARE COATED DECK ASSEMBLY	1
5	ZZCH0617	TRIANGULAR COATED DECK ASSEMBLY	1
6	ZZCH0618	1/2 HEX COATED DECK ASSEMBLY	1
7	ZZUN2290	COATED DECK TO DECK CONNECTION KIT	1
ADA Items			
8	ZZCH2007	TRANSFER STATION w/TALL GUARDRAIL (36in DECK)	1
9	ZZUN2019	APPROACH STEP FOR TRANSFER STATION	1
Slides			
10	ZZCH3126	GLIDE SLIDE (48in DECK)	2
11	ZZCH3127	GLIDE SLIDE (36in DECK)	1
Activity Panels			
12	ZZCH4458	TREASURE TUMBLE PANEL (GROUND LEVEL)	1
13	ZZCH4646	STORE FRONT PANEL	1
14	ZZCH4807	OVAL INSERT PANEL (DECK MOUNT)	1
15	ZZUN4796	OVAL BUBBLE PANEL INSERT	1
Crawl Tubes			
16	ZZCH5638	FUNNEL ADVENTURE TUBE 1ft RISE	1
Climbers			
17	ZZCH7439	ROCK CLIMBER (48in DECK)	1
18	ZZCH7657	SOLAR CLIMBER (36in & 30in DECK)	1
Audible Activities			
19	ZZCH4467	GROUND TO GROUND BABBLE-ON	1
20	ZZCH4557	8in BELL (POST MOUNT)	1
21	ZZCH4586	DRUM PANEL	1
Roofs & Arches			
22	ZZCH9846	CABANA ROOF	1
Additional Tool & Maintenance Kits			
23	ZZCHGUID	CHALLENGER GUIDELINES	1
24	ZZUN9910	SURFACING WARNING LABEL KIT	1
25	ZZUN9930	PIPE SYSTEMS MAINTENANCE KIT W/ AEROSOL	1

Discovery Place

Design Number: 350-1423D - Compliance and Technical Data

Reference Document: ASTM F1487

Ref. No.	Part No.	Qty.	Description	Unit ASTM Status	Total Weight (lbs)	Pre-Consumer Recycled Content (lbs)	Post-Consumer Content (lbs)	CO2e Footprint (kgs)	Users	Install Hours	Concrete (Yds3)	Active Play Events
1	ZZCH0018	1	3.5in OD x 124in STEEL POST W/RIVETED CAP	Certified	38.91			54	0	1.00	0.13	0
2	ZZCH0028	5	3.5in OD x 136in STEEL POST W/ RIVETED CAP	Certified	217.55			293	0	5.00	0.63	0
3	ZZCH0049	4	3.5in OD x 160in STEEL POST W/O CAP	Certified	199.64			254	0	4.00	0.50	0
4	ZZCH0616	1	SQUARE COATED DECK ASSEMBLY	Certified	54.86			174	3	1.00	0.00	0
5	ZZCH0617	1	TRIANGULAR COATED DECK ASSEMBLY	Certified	29.90			120	2	1.00	0.00	0
6	ZZCH0618	1	1/2 HEX COATED DECK ASSEMBLY	Certified	78.32			252	4	1.50	0.00	0
7	ZZUN2290	1	COATED DECK TO DECK CONNECTION KIT	Certified	0.29			4	0	0.50	0.00	0
8	ZZCH2007	1	TRANSFER STATION w/TALL GUARDRAIL (36in DECK)	Certified	148.40			310	2	2.00	0.09	0
9	ZZUN2019	1	APPROACH STEP FOR TRANSFER STATION	Certified	35.83			72	1	1.00	0.04	0
10	ZZCH3126	2	GLIDE SLIDE (48in DECK)	Certified	239.46			983	4	4.00	0.06	2
11	ZZCH3127	1	GLIDE SLIDE (36in DECK)	Certified	99.73			374	2	2.00	0.03	1
12	ZZCH4458	1	TREASURE TUMBLE PANEL (GROUND LEVEL)	Certified	53.28			848	1	2.00	0.00	1
13	ZZCH4646	1	STORE FRONT PANEL	Certified	33.98			243	3	1.00	0.00	1
14	ZZCH4807	1	OVAL INSERT PANEL (DECK MOUNT)	Certified	28.16			211	0	0.50	0.00	0
15	ZZUN4796	1	OVAL BUBBLE PANEL INSERT	Certified	5.87			114	0	0.50	0.00	0
16	ZZCH5638	1	FUNNEL ADVENTURE TUBE 1ft RISE	Certified	138.56			992	4	3.00	0.00	1
17	ZZCH7439	1	ROCK CLIMBER (48in DECK)	Certified	136.38			555	3	2.00	0.03	1
18	ZZCH7657	1	SOLAR CLIMBER (36in & 30in DECK)	Certified	79.63			236	2	1.50	0.03	1
19	ZZCH4467	1	GROUND TO GROUND BABBLE-ON	Certified	43.15			240	2	1.50	0.00	1
20	ZZCH4557	1	8in BELL (POST MOUNT)	Certified	5.15			44	1	0.25	0.00	1
21	ZZCH4586	1	DRUM PANEL	Certified	43.92			381	2	1.00	0.00	1
22	ZZCH9846	1	CABANA ROOF	Certified	76.05			390	0	0.50	0.00	0
23	ZZCHGUID	1	CHALLENGER GUIDELINES	N/A	0.00			1	0	0.25	0.00	0
24	ZZUN9910	1	SURFACING WARNING LABEL KIT	Certified	0.05			1	0	0.25	0.00	0
25	ZZUN9930	1	PIPE SYSTEMS MAINTENANCE KIT W/ AEROSOL	N/A				90				



Discovery Place

Design Number: 350-1423D - Compliance and Technical Data

Reference Document: ASTM F1487

Ref. No.	Part No.	Qty.	Description	Unit ASTM Status	Total Weight (lbs)	Pre-Consumer Recycled (lbs)	Post-Consumer Content (lbs)	CO2e Footprint (kgs)	Users	Install Hours	Concrete (Yds3)	Active Play Events
Totals:					1,787.07	202	356	7,232	36	37.25	1.53	11
					804.18 Kg	91 Kg	160 Kg	7 Metric Tons				1.16 m3



Discovery Place

Design Number: 350-1423D - Compliance and Technical Data

Reference Document: ASTM F1487

Ref. No.	Part No.	Qty.	Description	Unit ASTM Status	Total Weight (lbs)	Pre-Consumer Recycled Content (lbs)	Post-Consumer Content (lbs)	CO2e Footprint (kgs)	Users	Install Hours	Concrete (Yds3)	Active Play Events
----------	----------	------	-------------	------------------	--------------------	-------------------------------------	-----------------------------	----------------------	-------	---------------	-----------------	--------------------

ASTM F1487

The lay-out for this custom playscape, design number 350-1423D, has been configured to meet the requirements of the ASTM F1487 standard. In addition, each of the above components listed as "Certified" have been tested and are IPEMA certified. Components listed as "Not Applicable" do not fall within the scope of the ASTM F1487 standard and have not been tested. IPEMA certification can be verified on the IPEMA website, www.ipema.org. In the interest of playground safety, IPEMA provides a Third Party Certification Service which validates compliance.

2010 ADA Standards for Accessible Design

The lay-out was also designed to meet the 2010 Standards published 15-Sep-2010, by the Department of Justice when installed over a properly maintained surfacing material that is in compliance with ASTM F1951 "Accessibility of Surface Systems Under and Around Playground Equipment" as well as ASTM F1292, "Impact Attenuation of Surfacing Materials Within the Use Zone of Playground Equipment", appropriate for the fall height of the structure.

Installation Times

Installation times are based on one experienced installer. A crew of three experienced individuals can perform the installation within the given time, each member working 1/3 of the given hours. [Eg. Installation Time = 30 hours. For a crew of three, each member will work 10 hours on the installation for a total of 30 hours on the project.]

Carbon Footprint

The CO2e (carbon footprint given in Kilograms and Metric Tons) listed above is a measure of the environmental impact this play structure represents from harvesting raw materials to the time it leaves our shipping dock. Playworld Systems nurtures a total corporate culture that is focused on eliminating carbon producing processes and products, reducing our use of precious raw materials, reusing materials whenever possible and recycling materials at every opportunity. Playworld Systems elected to adopt the Publicly Available Specification; PAS 2050 as published by the British Standards Institute and sponsored by Defra and the Carbon Trust. The PAS 2050 has gained international acceptance as a specification that measures the greenhouse gas emissions in services and goods throughout their entire life cycle.

Pre-Consumer Recycle Content

A measurement, in pounds, that qualifies the amount of material that was captured as waste and diverted from landfill during an initial manufacturing process and is being redirected to a separate manufacturing process to become a different product. E.g. 100% of our Aluminum Tubing is made from captured waste material during the manufacturing process of extruded Aluminum products such as rods, flat bars and H-channels.

Post-Consumer Recycle Content

A measurement, in pounds, that qualifies the amount of material that was once another product that has completed its lifecycle and has been diverted from a landfill as a solid waste through recycling and is now being used in a Playworld Systems' product. E.g. **20% to 40% of the steel in our steel tubing and sheet steel have been diverted from landfills. Automobiles are scrapped and recyclable steel is purchased by the steel mill that produces our raw product.

** The amount of Post-Consumer recycled steel fluctuates daily based on the availability of the recycled steel.

